

Process description

Fine-Pitch Installation

Process description

QFP132 component exemplification

1. Install the ERSA PowerWell *i*-Tip ① in your *i*-Tool ② and set the temperature to 285°C (545°F) to 360°C (680°F). The set temperature depends on the alloy being used – lead free or not.
2. Place component ③ and fix two opposing corner pins.
3. Apply flux to the pins on all sides of the SMD. We recommend a No-Clean flux cream, or your approved flux.
4. Clean the entire front position of the ERSA PowerWell *i*-Tip, including concave, on a damp sponge or on the dry tip sponge. Fill the concave portion of the tip with solder wire, to slightly above the rim. DO NOT OVERFILL THE TIP! ④
5. Holding your *i*-Tool VERY LIGHTLY in your hand, set the filled tip, with the ERSA PowerWell side parallel to the PCB, down onto the flat exterior portion of the pins. *i*-Tool and tip should be parallel to the body of the SMD. Slowly pull the ERSA PowerWell across the pins towards you. ⑤ ⑥

The weight and form of the *i*-Tool and ERSA PowerWell *i*-Tip are designed to provide 100% joint integrity WITHOUT GUIDANCE and WITHOUT PRESSURE!

6. Repeat steps four and five for the remaining sides of the SMD. Remove flux residue if required.

Note: The size of the soldering tip should be adapted to the footlength L ⑤ and pitch of the lead!

Recommended equipment:

Type	Order no.
i-CON – single station	01C1000A
i-CON2* – double station	01C2000A
ERSA PowerWell tips	0102WDLF16, ...-23, ...-35;
Vacuum pipette SMD-Vampir	0SVP100
Vacuum pipette VAC-Pen	0VP020

*ERSA's product range offers further soldering irons, suitable for Fine-Pitch desoldering: Chip tool for SMD removal and X-Tool for standard through-hole desoldering.

Accessories:

Type	Order no.
No-Clean flux core cream	0FMKANC32-005
Solder wire	010MM0250LF02
Flux remover set	0FR200
No-Clean desoldering wick	0WICKNC2.2/10 bzw. 2.7/10

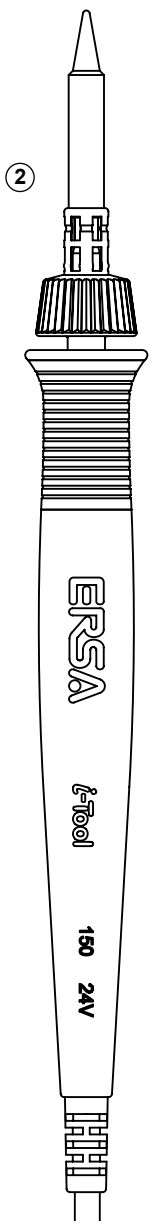
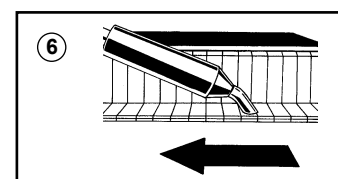
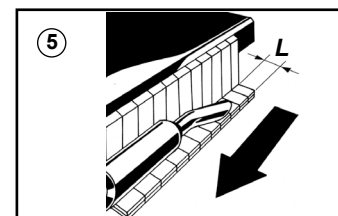
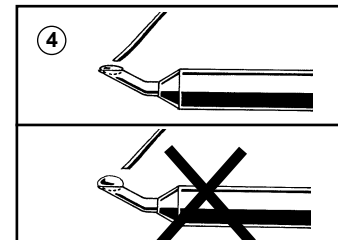
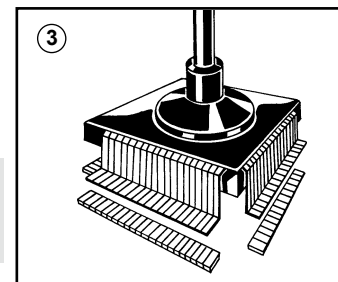
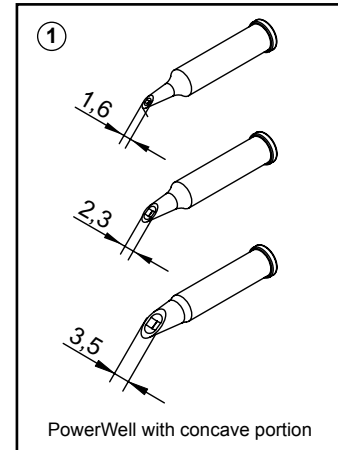

ERSA *i*-Tool